

 **MBS** TUBULAR
HEAT
EXCHANGERS





We strongly believe in innovation, always aware that in the field of thermal exchange new materials and process technologies may arise. We want to be an active player in this direction. We only aim for excellence, with the courage to admit mistakes and changing.



MBS STRENGTH

INNOVATION

Since its beginning, MBS has believed in the importance of research and development of new technology that delivers value and worth for the customer.

QUALITY AND KNOWLEDGE

Thanks to the skilled workmanship and the expertise of its team, MBS offers high-quality products.

CUSTOMER'S SATISFACTION

MBS aims to meet the customers' needs by offering technical and commercial support to ensure customized solutions in line with key industry regulations.

PRODUCTION EFFICIENCY

MBS has introduced a LEAN production system for several years now with a view to continuous production improvement.

Our history



1995
MBS establishment

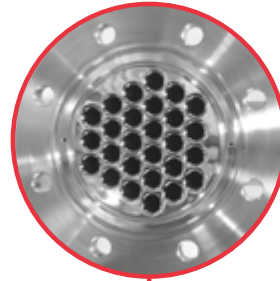

2008
Join CSF Inox group



1993-95

In partnership with the **University of Parma**, the effects of pipes scraping during thermal exchange are studied and thus a computing software is developed



1999

Heat Exchanger nr. 1000



2009

Production department in Godega di Sant'Urbano (Treviso)

2011

Manufacturing of the first
Scraped Heat Exchanger

Hercules series



2016

- Opening **Flow Technology Components Mexico** (FTC Mexico) branch commercial office

- **EHEDG** certification



2019

Manufacturing of the
first **DOUBLE** scraped
surface heat exchanger
"HERCULES" series



2014

MBS obtains **ISO 9001:2015**

Certification for quality
Company Organization



2018

- Parma's new head office
- **3-A** certification



CSFinoxGroup

FLOW TECHNOLOGY COMPONENTS

Joining CSF's GROUP, MBS starts its expansion and entry into international markets.

CSF Inox Group aims to produce and sell components (Pumps, Valves, Heat Exchangers) to the hygienic and sanitary industry sectors such as: Food, Beverage, Cosmetic, Pharmaceutical and Bio-Technologies.







FOOD AND BEVERAGE



PHARMA

Corrugated Tubular Heat Exchanger

Corrugation is the process of creating an internal corrugated surface inside smooth tubes, which allows a higher flow turbulence, improving the heat exchange efficiency.

The MBS Heat Exchanger sizing is carried out through a sophisticated calculation software, constantly improved and updated thanks to the decennial co-operation with Parma's University (Technical Physics Department)



INDUSTRIAL



SCRAPED SURFACE

Plus

- Reduction of the required areas
- Contact times and product's permanence reduction inside the item
- Reduced washing times due to a higher mechanical action generated by turbulence
- Vertical or horizontal installation
- Ability to work with high pressures and temperatures
- Minimum maintenance cost due to gasket-free design
- Ease of assembly and modularity of the exchanger

FOOD & BEVERAGE

MBS Heat Exchangers range is designed and manufactured for the Food industry according to the strictest hygienic standards. Suitable for processing high and medium viscosity products such as milk, juices, nectars and fruit puree, wine, beer, cream, ice cream etc.

MLW version is EHEDG and 3A certified.

STANDARD TECHNICAL FEATURES

Material Product side.....**AISI 316L**
(other materials supplied on request)

Finishing Product side.....**Ra < 0,8 µm**

Pressure Project.....**10 bar**

Max temperature project.....**184°C**





SANITARY MIXFLO MONOTUBE MNW SERIE

Monotube mixflo Heat Exchanger consists in two concentric corrugated tubes.

The product to be thermally treated flows inside the smaller tube while service fluid flows into external jacket.

Particularly suitable for products having a **medium or high viscosity** even with particulates in suspension such as **pressed grapes, fruit and vegetables concentrate**.

SANITARY MIXFLO MULTITUBE MLW SERIE

Multitube mixflo Heat Exchanger consists of small corrugated tubes inside a shell welded from one end to the other. An expansion joint is fitted on the external shell.

Particularly suitable for products having a **medium or low viscosity** even with pulps and fiber, small particulates such as **milk, juices, nectar, cream, sugar solutions etc.**



FOOD & BEVERAGE



MULTITUBE MIXFLO DISASSEMBLED

Manufactured with small corrugated tubes placed inside the shell.
The tube bundle can be removed from the shell. It is not equipped with expansion joint due to floating plates.

Particularly suitable for products having a **medium or low viscosity** even with pulps, fiber, small particulates such as **milk, juices, nectar, cream, sugar solutions etc.**

MIXFLO SANITARY ANULAR SPACE SERIE

Manufactured with 3 or 4 corrugated concentric tubes. Product side can be examined.
Installed expansion joint on the external shell.

Particularly suitable for products having a **medium or high viscosity** even with particulates such as **fruit or vegetable concentrates, ketchup etc.**



PHARMA

MBS Heat Exchangers range is designed and manufactured for the pharmaceutical industry according to the strictest hygienic standards Particularly suitable for products having a low viscosity such as: injectable water, ethanol, protein solutions etc.

MLP version is EHEDG and 3A certified

STANDARD TECHNICAL FEATURES

Material Product side.....**AISI 316L**
(other materials supplied on request)

Finishing Product side.....**Ra < 0,8 µm**

.....**Ra < 0,5 µm electro polished**

Pressure Project.....**10 bar**

Max temperature project.....**184°C**



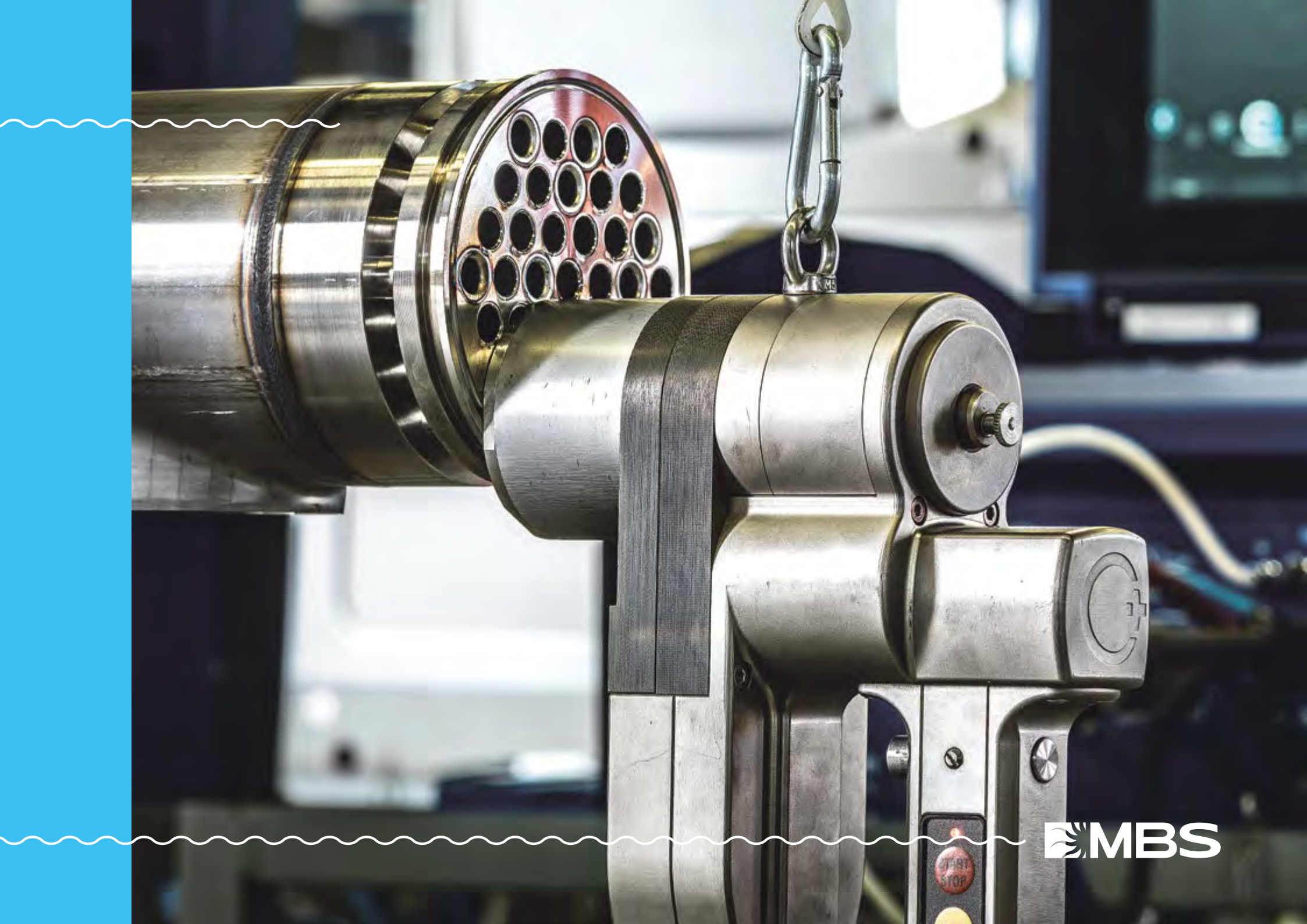

MLP MULTITUBE

Manufactured to meet pharmaceutical industry standards of **hygienic and safety demands.**

PHARMAFLO Heat Exchanger consists of small diameter corrugated tubes inside a shell with plates on both ends.

With this design all kind of contamination between sterile product and service fluid is avoided.

Particularly suitable for products having a **medium or low viscosity such as wfi, point of use cooling, wfi heating, condensation, protein solution etc.**



PHARMA





INDUSTRIAL



MBS Heat Exchangers range is designed and manufactured for the industrial field according to the highest construction standards.
Particularly suitable for CIP, combustion gases, process water, biogas, oils etc.

STANDARD TECHNICAL FEATURES

Material Product side.....**AISI 316L**

(other materials supplied on request)

Finishing Product side.....**Brushed**

Pressure Project.....**10 bar**

Max temperature project.....**184°C**





 mbs

 **MBS**

CROSSFLO INDUSTRIAL MULTITUBE MLI SERIE

Manufactured with small corrugated tubes placed inside the shell welded from one end to the other. An Expansion joint is fitted on the external shell.

Particularly suitable for products having a **medium or low viscosity** such as **water, cip, oils, gases, combustion gases etc.**

MULTIFLO INDUSTRIAL MULTITUBE MULTIPASSAGING MLM SERIE

Manufactured with small corrugated tubes placed inside the shell welded from one end to the other.

The MULTIFLO exchanger is multi-passaging and the exchange is as result of the special headboards.

Particularly suitable for products having a **medium or low viscosity** such as **water, cip, oils.**



INDUSTRIAL

MULTIFLO U TUBES MLU INDUSTRIAL

The MULTIFLO U can be disassembled and “U” shaped the tube bundle inside the shell is easily removable for any maintenance.

Particularly suitable for products having a **medium or low viscosity** such as **water, cip, oils.**



SCRAPED SURFACE HEAT EXCHANGER

Hercules

For the Hercules project, we worked closely with Parma University by means of extensive research to develop better heat exchange parameters, power absorptions and materials studies in presence of the tested products.





mbs

 MBS

HERCULES

Particularly suitable for products having **high viscosity, with particulates in suspension** and the tendency to adhere to the exchange surfaces, in order to turn the process from **“batch” into “continuous”**.

Products such as: **jams, ketchup, mayonnaise, soups, dressings, chocolate, meat sauces, gelatins, baby food, honey, butter, curds, ice cream, oils, fats.**

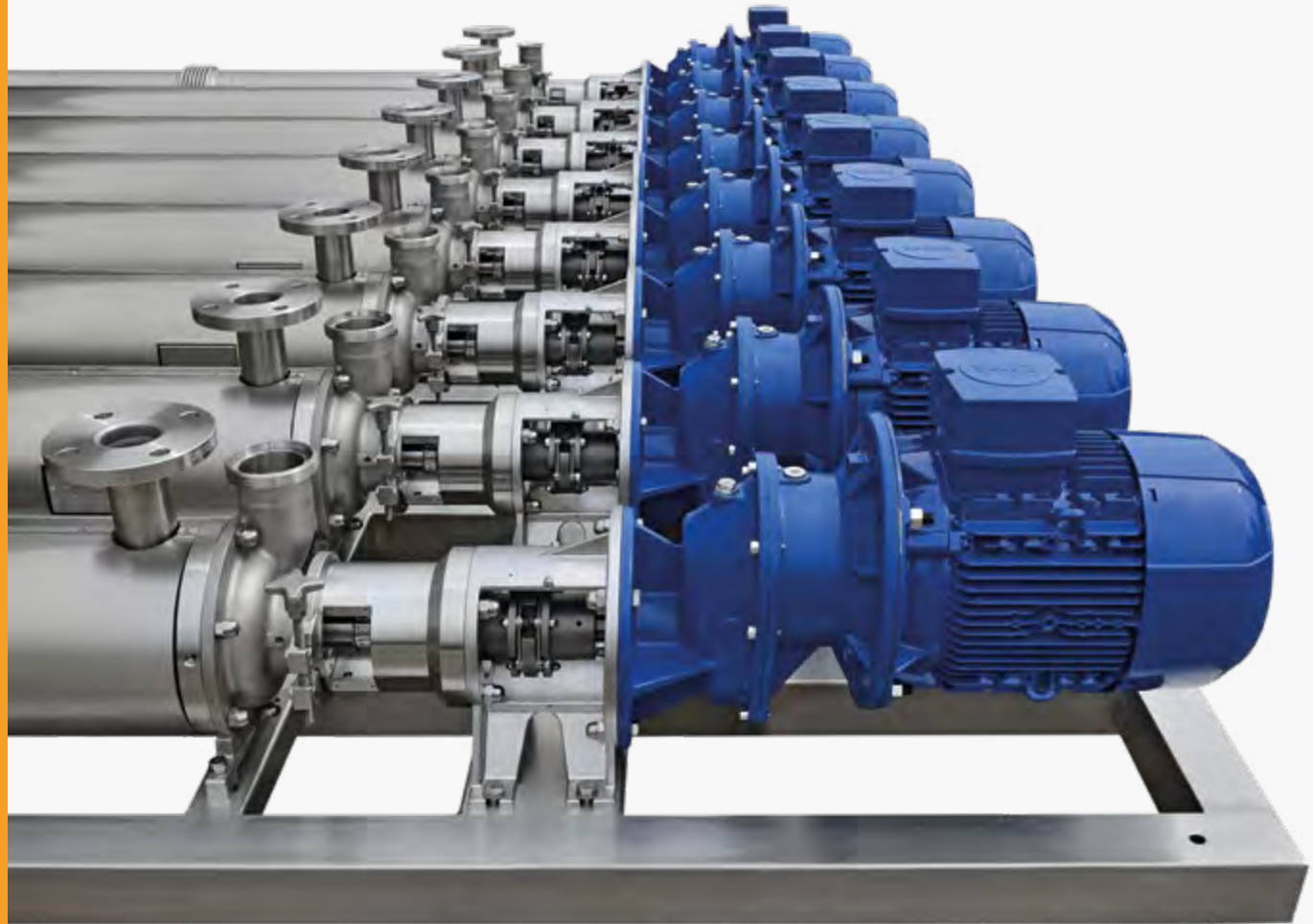

SCRAPED
SURFACE



Model	DIMENSION (mm)									PRODUCT		SERVICE	
	A	B	C	Exchange Surface	D	E	F	G	H	P MAX	T MAX	P MAX	T MAX
H5	1000	840	1082	0,5 m ²	DIN 11851 DN 65 F CLAMP 3"	EN 1092-1 DN 50 PN 16	400	2350	482	19,5	184	10	184
H10	2000	1840	2082	1 m ²				3350					
H15	3000	2840	3082	1,5 m ²				4350					
H30	1370	1138	1503	3,2 m ²	DIN 11864-2 2" 1/2	EN 1092-1 DN 40/32 PN 16	950	1500	2517	15	160	8	172
H45	1900	1666	2031	4,5 m ²				3045					

H30-H45

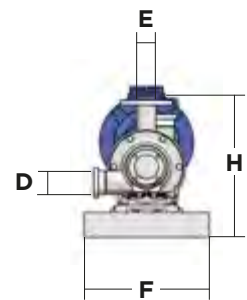
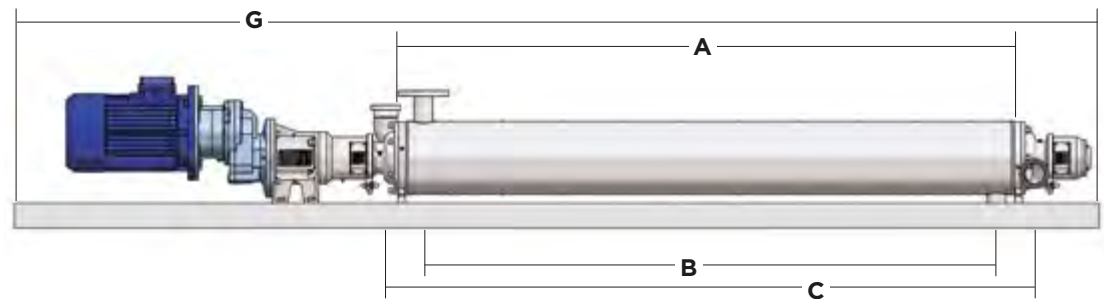

H5-H10-H15

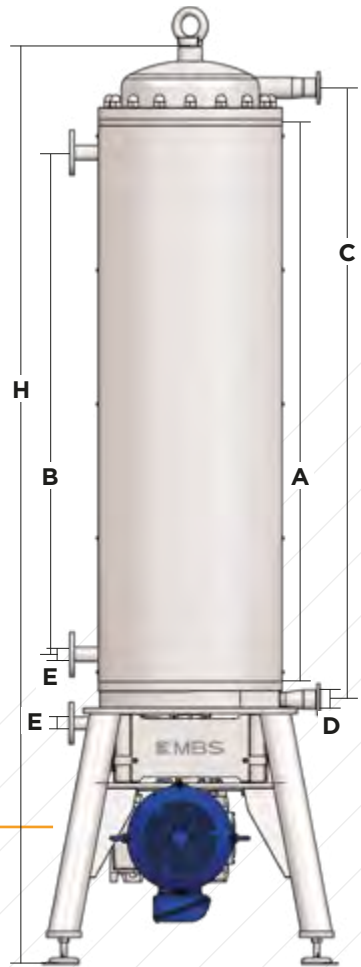
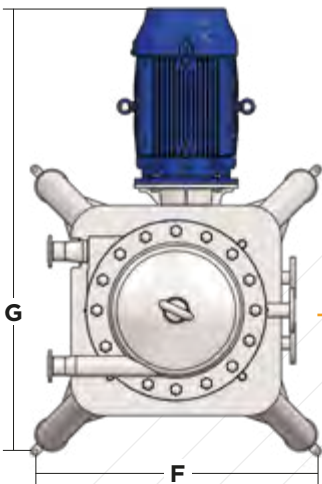

RESEARCH AND DEVELOPEMENT

Certificates

The following certificates acquired by MBS are showing our compromise to a constant improvement both operational and industrial.
All the exchangers are compliant with PED 2014/68/UE.



Co-operation

MBS has cooperated from more than 25 years with Parma University. Thanks to this co-operation, in particular with Technical Physics, we developed our products on an adequate scientific basis.





Hygienic Process Systems B.V.

Tinstraat 6
4823AA Breda
The Netherlands

Tel: +31 (0)85 483 5801
info@hyprosys.com | www.hyprosys.com