

ROTARY HEAD 24 SERIES

Tanks and cisterns washing system

Construction:

The rotary spray heads are made of AISI316L stainless steel and are mounted onto two bearings. All internal surfaces are carved with high precision machine tools, which provide a smooth polishing and high quality surfaces. The heads are available with different joint solutions: female gas thread (BSP), clip or socket welding.



Operation:

The fluid Flow Rate through the rotary head produces the rotation. Its speed varies depending on the washing fluid pressure that needs to be limited. An excessive speed in the rotation breaks the Flow Rate into drops, reducing the impact strength.

Technical characteristics:

Max working temperature 95°C – Min working temperature 0°C

The weight of the rotary head series 24 can vary from 0.15 to 0.25 kg depending on the model.

ROTARY HEAD 24 SERIES

Tanks and cisterns washing system



180° ▼



360°

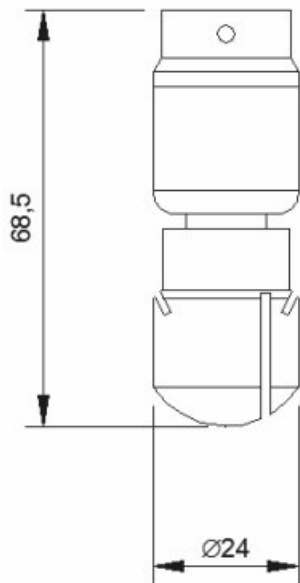

Clip / Welding

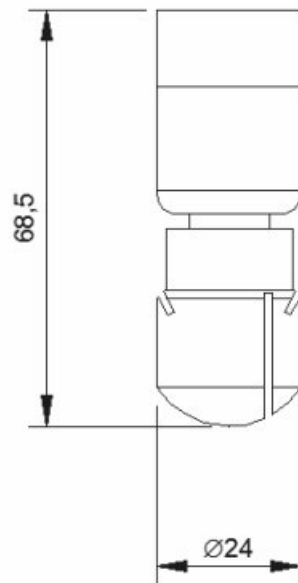

Female

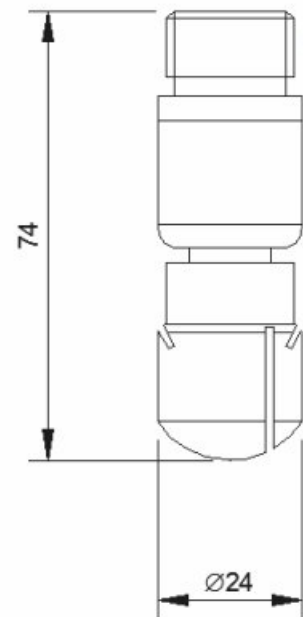

Male

ROTARY HEAD 24 SERIES

Tanks and cisterns washing system

SERIES 24 - GAS THREAD (BSP)							
	Flow Rate (lt/h)			Angle	Max washing	Joints	
Pressure (Bar)	1	2	3		range**	Fem.	Male
Code				(Degrees)	(meters)		
24 3/8M O	2400	3100	4000	360°	1,3 ÷ 2,2		3/8"
24 3/8M D	1600	2250	2750	180° ▼	1,3 ÷ 2,2		3/8"
24 1/2M O	2400	3100	4000	360°	1,3 ÷ 2,2		1/2"
24 1/2M D	1600	2250	2750	180° ▼	1,3 ÷ 2,2		1/2"
24 1/2 O	2400	3100	4000	360°	1,3 ÷ 2,2	1/2"	
24 1/2 D	1600	2250	2750	180° ▼	1,3 ÷ 2,2	1/2"	

SERIES 24 - CLIP						
	Flow Rate (lt/h)			Angle	Max washing	Joints
Pressure (Bar)	1	2	3		range**	Øe Pipe
Code				(Degrees)	(meters)	(mm)
24 C13 O	2400	3100	4000	360°	1,3 ÷ 2,2	Ø12,7
24 C13 D	1600	2250	2750	180° ▼	1,3 ÷ 2,2	Ø12,7
24 C19 O	2400	3100	4000	360°	1,3 ÷ 2,2	Ø19,05
24 C19 D	1600	2250	2750	180° ▼	1,3 ÷ 2,2	Ø19,05
24 C21 O	2400	3100	4000	360°	1,3 ÷ 2,2	Ø21,3
24 C21 D	1600	2250	2750	180° ▼	1,3 ÷ 2,2	Ø21,3

SERIES 24 - TO WELD						
	Flow Rate (lt/h)			Angle	Max washing	Joints
Pressure (Bar)	1	2	3		range**	Øe Pipe
Code				(Degrees)	(meters)	(mm)
24 S13 O	2400	3100	4000	360°	1,3 ÷ 2,2	Ø12,7
24 S13 D	1600	2250	2750	180° ▼	1,3 ÷ 2,2	Ø12,7
24 S19 O	2400	3100	4000	360°	1,3 ÷ 2,2	Ø19,05
24 S19 D	1600	2250	2750	180° ▼	1,3 ÷ 2,2	Ø19,05
24 S21 O	2400	3100	4000	360°	1,3 ÷ 2,2	Ø21,3
24 S21 D	1600	2250	2750	180° ▼	1,3 ÷ 2,2	Ø21,3